



EUROCHAIN VR[®]

Electric chain hoist for loads
from 63 to 10,000 kg



EUROCHAIN VR[®]



Electric chain hoist for loads from 63 to 10,000 kg

Completely innovative, top of the range design, its fluid, contemporary and elegant lines confirm the power of this electric chain hoist. This new generation of EUROCHAIN VR hoists is the result of innovative technology ; new materials, new operating concepts, can adapt to each specific need.



◀ Phase 1



With EUROCHAIN VR12 phase 2, dimensions reduction about **30%**.



◀ Phase 2

- > Optimize and better organization of product offering for EUROCHAIN VR range (VR2, VR5, VR12). Range update with addition of new 2-fall products VR2 (500 kg) and VR5 (1000 kg).
- > Better integration of current options (lighting, radio, klaxon,...) compare to phase 1. New options (IP 66 protection, Short headroom trolley,...) will be available on phase 2.
- > Product improvements : tilted position of the hoist and size of body reduced by 30% on VR12 (compare to phase 1).

Technical characteristics

The EUROCHAIN VR electric chain hoist is designed to provide users with the maximum level of safety. It is delivered with the following equipment as standard :

- > New lifting nut concept with intermediate teeth for perfect chain drive.
- > Torque limiter.
- > Disk lifting brake.
- > 3 m standard lifting height.
- > Dual-speed lifting.
- > Safety electric end of run for up and down position.
- > IP55 lifting and travelling motor.
- > Thermal protection on lifting motor.
- > Tropic-proof protection (lifting and steering - 90 to 95 %).
- > Galvanised lifting chain.
- > Disconnectable command cable.
- > 2-buttons unit on fixed hoist or push steering carriage.
- > 4-buttons unit on hoist coupled to electric steering carriage.
- > Emergency stop button.
- > 400V/3Ph/50Hz or 415V/3Ph/50 Hz or 460V/3 Ph/60 Hz power supply.
- > Low voltage 48 V command.
- > Chain bag.
- > 70 mm, RAL 7021 epoxy powder paint.
- > Speed variation on travelling - MS Mode (for hoists with an electric trolley).
- > Complies with the CE machine directive.



EUROCHAIN VR5
mounted on VFTS jib crane
with EUROSYSTEM profile

+ speed

Wide range of speeds.

25% quicker than the previous generation: 4/1,3; 8/1,3; 8/2; 10/1,6; 10/2,5; 16/2,7; 16/4; 20/5.

The lifting speed ranges have been considerably expanded to enable them to better meet your production constraints and increase productivity, performance, safety and usage on a daily basis.

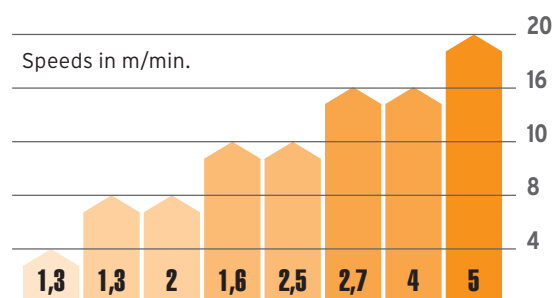

+ savings

Maintenance operations are now simpler, quicker and more economical:

- > Easy access to the brake setting.
- > Easy access to the clutch setting.
- > Easy access to the fuse.
- > Access (workspace) and easy removal of the electric boards by removable plug.

EUROCHAIN VR25
for load
up to 10,000 kg
in combined version



+ power

Lifting capacities.

The load spectra for each hoist body have been revised upwards to optimise your lifting equipment investment.

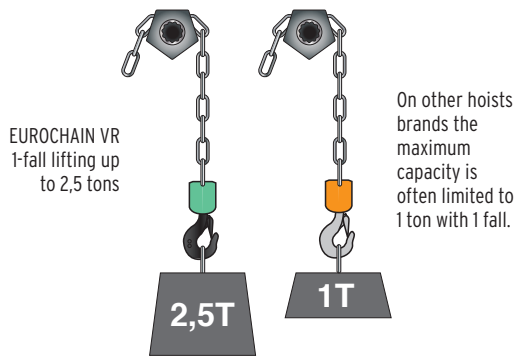

1-fall lifting up to 2.5 tons in FEM 3m.

This product advantage offers you the possibility of working at greater lifting heights, with the following benefits :

- > Reduction in chain bag dimensions, with a more compact lifting unit.
- > Reduction in maintenance costs (fewer lifting chains to be replaced if necessary during maintenance operations).
- > Elimination of lifting hook tip-over risks.
- > High lifting speeds preserved.

FEM user group up to 3m.

For intensive use of your hoist, up to 300 start-ups per hour !

Long lifetime.

Lifetime of hoist components is extremely high in order to optimize your return on investment.

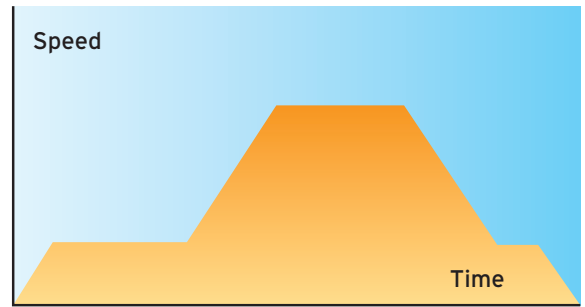
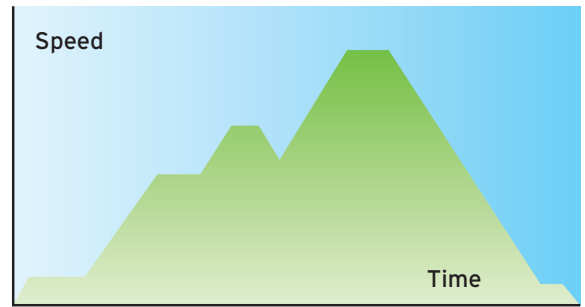

+ safety

Clutch concept.

The clutch position in the reducer ensures the load is held by the brake regardless of the machine's daily operating conditions.

Low voltage or direct voltage command.

Enables perfect operation for your usage context (operation in industrial environment, stage lifting, etc.).

Variable speed electric travelling.

The variable speed travelling combined with the high lifting speeds enables flexible and quick working in complete safety for the operator.





new design

modularity

Electric unit

The printed circuit boards have removable plugs to facilitate maintenance operations. The side flanges can also be removed easily for all interventions (the flanges are fitted with anti-drop type steel safety cables). Low voltage command (48V) for more safety.

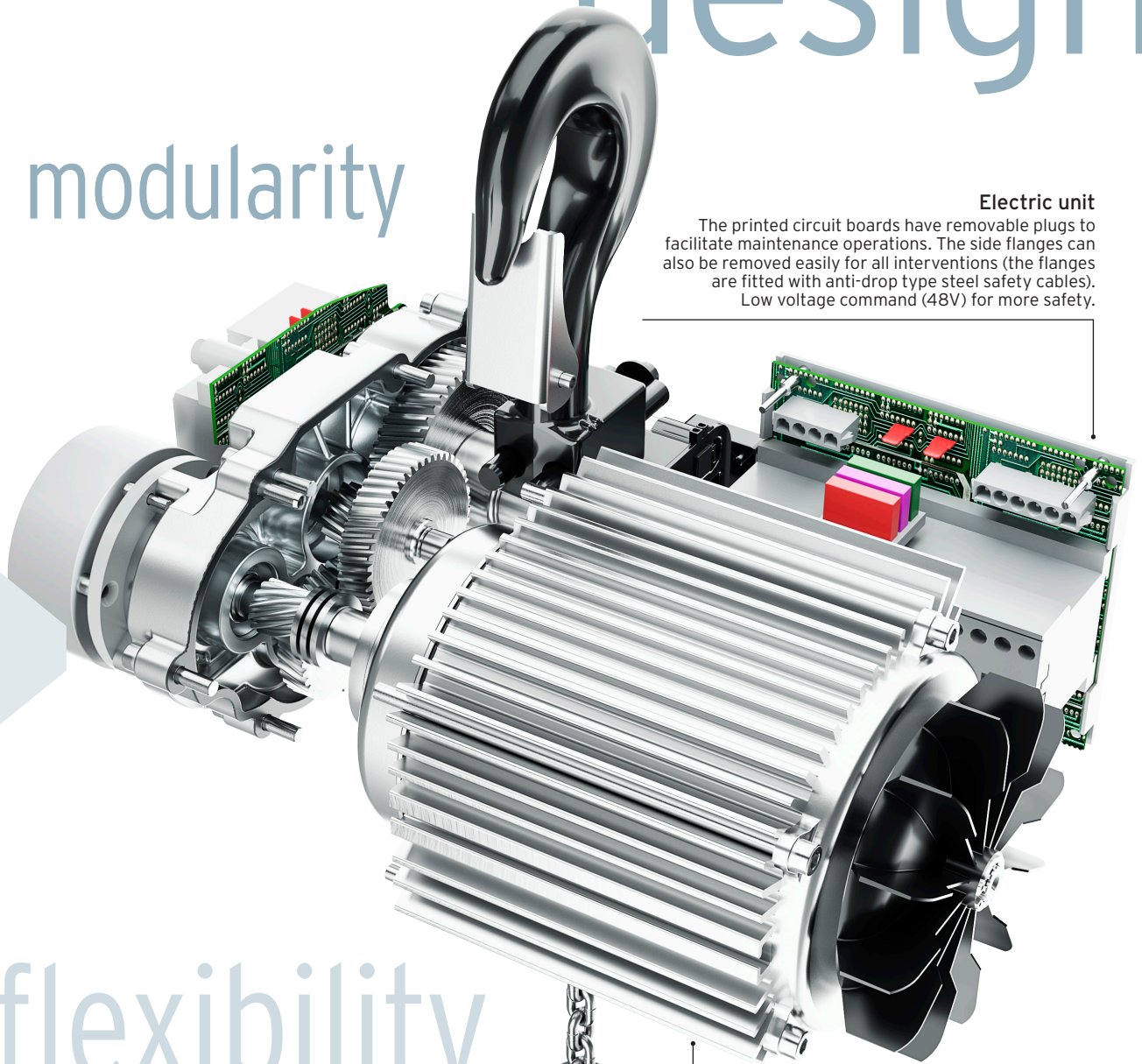

flexibility

Lifting hook

Lifting hook with ergonomic gripping zone, better protection for the lifting block by rubber coating. The lifting hook is larger for easier connection with the under hook lifting accessories. The upper cone has a dual function, activation of the electric limit switch and collection of the surplus oil used to lubricate the chain.

Lifting motor

Dual-speed as standard for smoother operation and higher productivity. The motor's forced ventilation is provided by a fan at the end of the shaft and a developed air evacuation circuit (side and front vents).

These technical choices provide optimum cooling to the hoist body and an increased lifetime for the lifting motor. The motor device, which can also be dismantled for all replacement or maintenance operations, is fitted as standard with a thermal protection.



Pendant unit

Available in a 2, 4 or 6-buttons version depending on whether the hoist operates in fixed hooked position, travel trolley on monorail or crossing crane with sideways movement or electric rotation jib.
P65 protection as standard, 48 V low voltage command and removable plug.

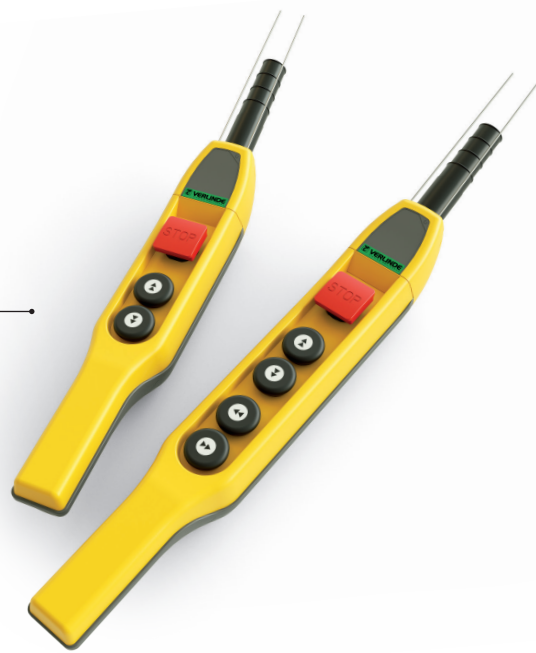

practical ergonomical



Hoist body

The design with its completely fluid and stripped-down lines emphasises the visible signs of robustness and embedded technology and strengthens the feelings of safety given. The hoist body, which is protected by 70µm epoxy powder paint, is able to operate in aggressive thermal environments (-20C° to +50 C°). This hoist complies with ecology regulations (RoHS compatible).

environmentally-friendly robustness



reddot design award

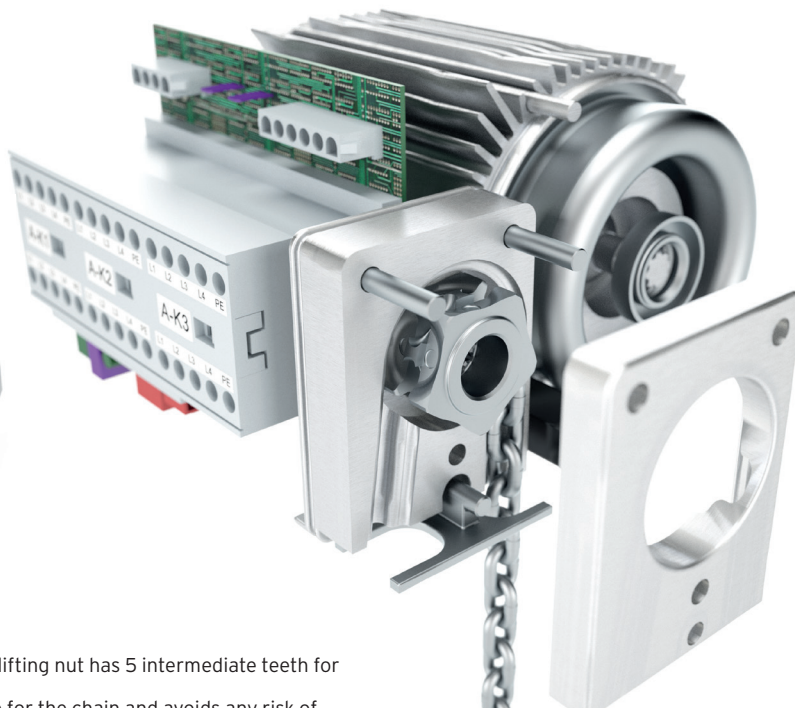

Load wheel, electric limit switch

A new patented concept, the 5-pockets lifting nut has 5 intermediate teeth for perfect control over the lifting chain. This innovation enables better guidance for the chain and avoids any risk of jamming. Increased operating safety and reduced maintenance costs. The lifting hook's maximum up and down positions are secured by the electric limit switch located under the chain guidance system. The switches are activated alternately by the lifting hook's upper cone and the slack fall stop.





innovation

Gear box, clutch and brake

The reducer, which is lubricated lifetime (to reduce maintenance operations) has been designed for extremely long operating periods (up to 3200 hours).

The high precision machining on the gear trains also guarantee operation with a very low level of noise annoyance.

The clutch is very easy to access for the occasional maintenance operations.

Its position in the reducer ensures the load is held by the brake regardless of the machine's operating conditions.

The lifting disk brake has been tested for the hoist's lifetime to reduce maintenance operations and provide an increased level of safety.

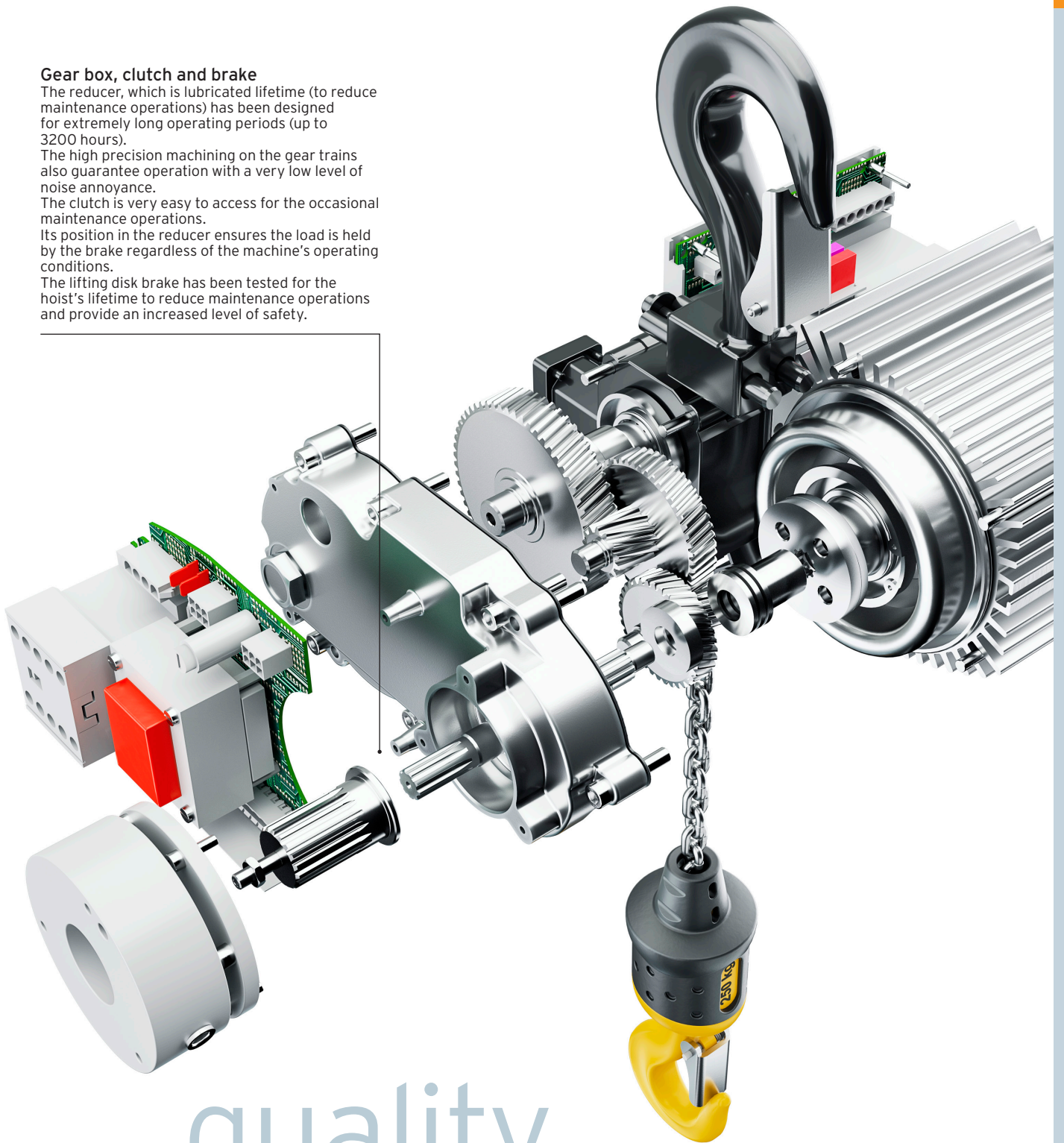

quality
safety



► Taylor-made declination



EUROCHAIN VRS

► Fixed suspended by hook.



EUROCHAIN VR25

► Fixed suspended by hook.



► Hooked to motorized or hand operated trolley in Eurosystem ST profile.



► Hooked to motorized or hand operated trolley in Eurosystem ALU profile.



► Hooked to hand operated or geared trolley on I beam.



► Coupled to motorized trolley on I beam.



► Combined hoist for increased capacity up to 10,000 kg coupled to motorized trolley on I beam.

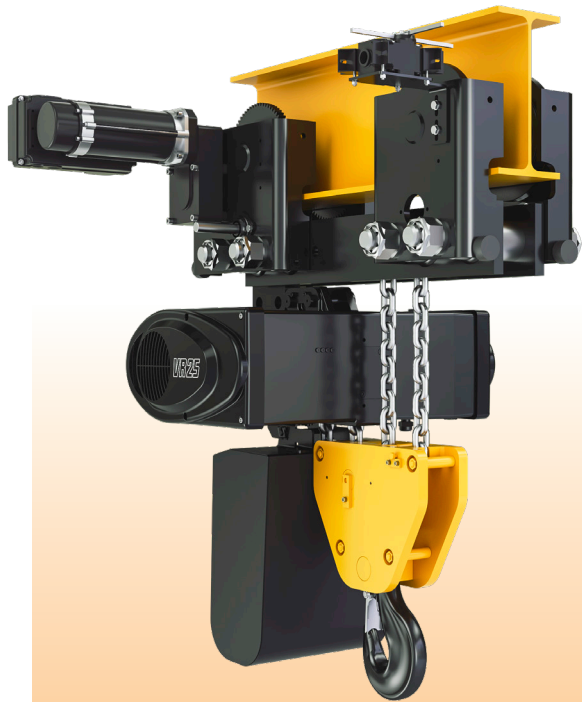

➤ 3 falls hoist body for increased capacity up to 7,500 kg coupled to motorized trolley on I beam.

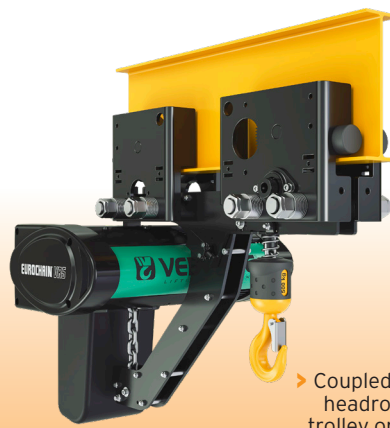

➤ Coupled to short headroom push trolley on I beam.

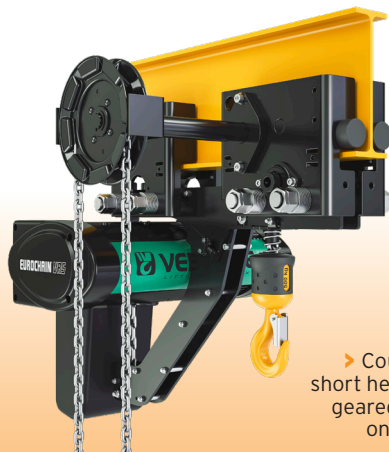

➤ Coupled to short headroom geared trolley on I beam.



➤ Coupled to swivelling motorized trolley on curved beam.



➤ Coupled to short headroom motorized trolley on I beam.



➤ Coupled to double girder motorized trolley on crane.



DIGICHAIN®

Electric chain hoist
with hand positionner
on hooks for loads
up to 500 kg



+ ergonomics

A workstation meeting fully the demanding requirements of today's users. With DIGICHAIN and positionner on hook your loads ranging from 63 to 500 kg can be effortlessly positioned with spot-on accuracy. The orientation of the hoisting hook and handling grip can be suitably adapted by means of the adjustment screw. 100% safety The DIGICHAIN handling system enables you to lift your loads up to a height of 5 meters.

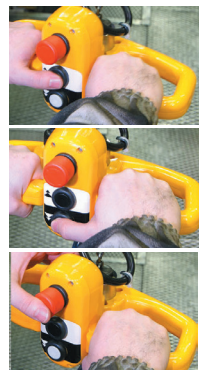

+ safety

The DIGICHAIN handling system enables you to lift your loads up to a maximum height of 5 meters.

- > Coil-formed control cable eliminates all risk of snarling up.
- > Upper and lower limits switches, for greater operating safety.
- > Hoisting hook can be dismantled and replaced with other hoisting or gripping tools.
- > Low Voltage 48 volt control system ensuring maximum operator safety.

Technical characteristics

- > Load capacity : 63 to 500 kg.
- > Maximum hoisting height : 5 meters.
- > Upper and Lower limit switches.
- > Dismountable hoisting hook.
- > 48 volts Low voltage control system.
- > Weight : 3.2 kg.
- > Storage temperature : -40°C to +60°C.
- > Service temperature : -20°C to +40°C.
- > Relative humidity : 90%.
- > Maximum side pull operability : 3 degrees.

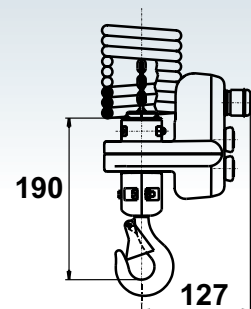
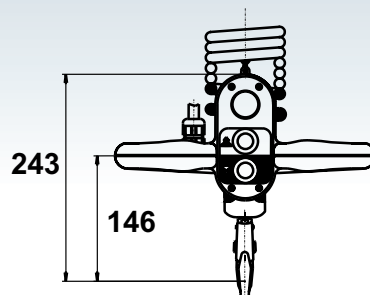
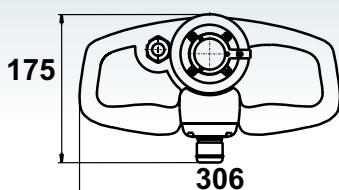

VARIO®

Electric chain hoist Stepless lifting speed



+ productivity

Continuous speed control offers starting without jerking, rapid accelerations and gentler stopping, to optimize load-handling operations. ESR system allow adaptation of deceleration ramp and offer faster lifting speed with lighter load (up to 200%).

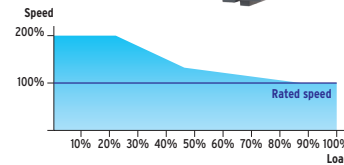

+ lifetime

Continuous speed control reduces mechanical impacts thanks to gradual starting and gentler stopping. The lower numbers and extents of impacts on the components of the bridge or structure considerably lengthen the service life of the frame.

+ savings

Continuous speed control enables electric braking to be used as priority when decelerating before applying the mechanical brake. Electric braking reduces brake wear since the mechanical brake is used only as holding brake (parking brake).

Technical characteristics

- > Stepless hoisting speed through inverter control.
- > Adjustable acceleration/deceleration ramp time.
- > EP, MS or analog control modes with load adaptive ESR functionality.
- > Brake control with supervision.
- > Over speed supervision.
- > Clutch slippage supervision.
- > Electronic overload prevention through load sensor.
- > Programmable hoisting limits set by pendant (available at a later phase).
- > Shock load control.
- > Hour counter, start counter, SWP calculation.
- > Active polygon damping, 50% reduction (only for Europe).
- > Power supply 380 to 480V/3Ph/50Hz 60 Hz.
- > Low voltage control 48 V (115 or 230 as option).
- > Variable travelling speed on electric trolley.

Capacity (kg)	Hoist type	Group		Lifting speeds (m/min)	ESR speeds (m/min)	ESR loads (kg)	Number of falls	Gear box lifetime (hours)	Chain dimensions
		FEM	ISO						
125	VR5 1224 V2	2m	M5	0,64 → 24	32	80	1	1600	4 x 11
250	VR 5 2516 V2	2m	M5	0,64 → 16	32	80	1	1600	4 x 11
320	VR 5 3212 V1	1Am	M4	0,64 → 12,5	32	80	1	800	4 x 11
500	VR 5 508 V2	2m	M5	0,32 → 8	16	160	1	1600	5 x 14
500	VR 12 5016 V2	2m	M5	0,63 → 16	32	160	1	1600	7 x 20
630	VR 5 636 V1	1Am	M4	0,32 → 6,5	16	160	1	800	5 x 14
630	VR 12 6312 V1	1Am	M4	0,63 → 12,5	32	160	1	800	7 x 20
800	VR 12 809 V2	2m	M5	0,31 → 9	16	320	1	1600	7 x 20
1000	VR 5 1004 V2F	2m	M5	0,16 → 4	8	320	2	1600	5 x 14
1000	VR 12 1008 V2	2m	M5	0,31 → 8	16	320	1	1600	7 x 20
1250	VR 12 1256 V1	1Am	M4	0,31 → 6,5	16	320	1	800	7 x 20
1600	VR 12 1604 V2	2m	M5	0,16 → 4,5	8	630	2	1600	7 x 20
2000	VR 12 2004 V2	2m	M5	0,16 → 8	8	630	2	1600	7 x 20
2500	VR 12 2503 V1	1Am	M4	0,16 → 16	8	630	2	800	7 x 20

new





EUROCHAIN VR[®] INOX

Electric chain hoist
for loads from
63 to 10,000 kg

Technical characteristics

- > Stainless steel lifting chain.
- > New lifting nut concept with intermediate teeth for perfect chain drive.
- > Torque limiter.
- > Disk lifting brake.
- > 3 m standard lifting height.
- > Dual-speed lifting.
- > Safety electric end of run for up and down position.
- > IP55 lifting and travelling motor.
- > Thermal protection on lifting motor.
- > Tropic-proof protection (lifting and steering - 90 to 95 %).
- > Disconnectable command cable.
- > 2-buttons unit on fixed hoist or push steering carriage.
- > 4-buttons unit on hoist coupled to electric steering carriage.
- > Emergency stop button.
- > 400V/3Ph/50Hz or 415V/3Ph/50 Hz or 460V/3 Ph/60 Hz power supply.



Options

- > Stainless steel lifting hook.
- > Biodegradable oil NSF H1 or dedicated for food (lifting and travelling gearbox, lifting chain). Lubricant clean and bubble for chains, sprockets and guides in the industry food. Oil synthetic anti-wear and extreme pressure, usable for incidental contact with the foodstuffs following the FDA requirements (certificates available on request).
- > Stainless steel load wheel on trolley hoist and accessory white finish Paint.
- > Level of protection increased : ATEX Zone 1, EEx.
- > Level of protection increased: ATEX Zone 22.
- > IP66 protection.
- > Variable speed lifting.
- > Extreme operating temperatures: (-40 °C to +70 °C).
- > Wall control panel instead of the pendant.
- > Remote radio control.
- > Manual or electric trolley.



Hoists dimensions

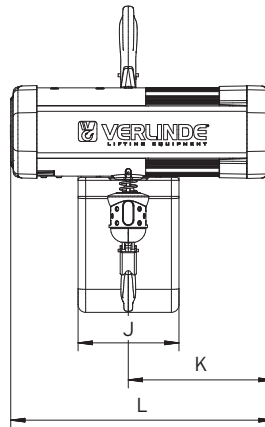
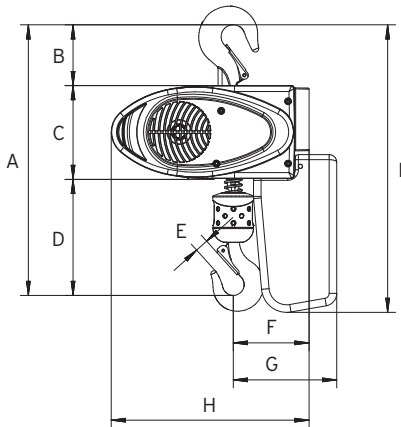

EUROCHAIN
VR2
VR5
VR12

Hoist type	Chain dimensions	Chain bag capacity (m)	Max. loading (kg)	Dimensions (mm)												
				A	B	C	D	E	F	G	H	I	J	K	L	
VR2	4 x 11	8	250	376	86	56	76	186	18	131	300	380	219	230	411	-
	4 x 11	8	500	376	86	56	76	186	18	131	300	380	219	230	411	-
VR5	5 x 14	6/16/25	630	445	107	156	182	21	138	161	362	489/554/674	150	230	438	570
	5 x 14	6/16/25	1000	506	107	156	243	27	123	184	362	489/554/674	150	230	438	570
VR12	7 x 20	6/16/30	1250	537	121	186	230	27	150	205	392	570/711/781	200	287	520	653
	7 x 20	6/16/30	2500	607	121	186	300	33	154	236	392	570/711/781	200	287	520	653

Standard version VARIO version

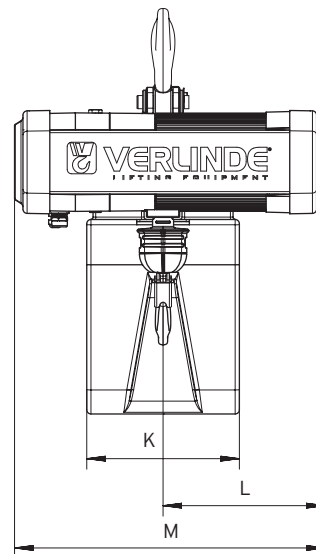
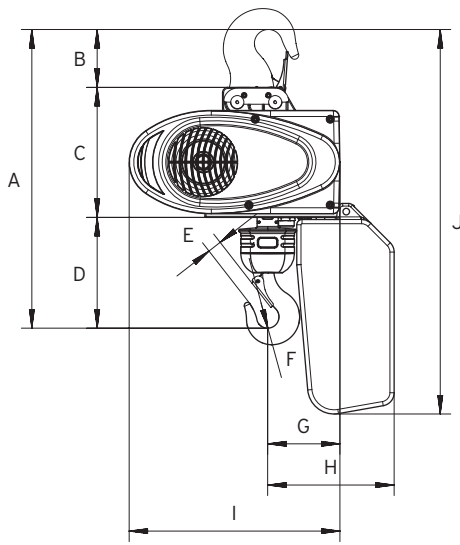

EUROCHAIN
VR16
VR25

Hoist type	Chain dimensions	Number of falls	Chain bag capacity (m)	Max. loading (kg)	Dimensions (mm)												
					A	B	C	D	E	F	G	H	I	J	K	L	M
VR16	7 x 20	1	12	1250	614	110	247	257	28	21	137	240	400	730	290	308	590
	7 x 20	1	30	1250	614	110	247	257	28	21	137	315	400	905	300	308	590
	9 x 27	1	12	1600	567	110	247	210	26	22	138	240	400	730	290	308	590
	9 x 27	1	30	1600	567	110	247	210	26	22	138	315	400	905	300	308	590
	9 x 27	2	12	3200	693	110	247	336	35	25	179	282	400	730	290	308	590
	9 x 27	2	30	3200	693	110	247	336	35	25	179	357	400	905	300	308	590
VR25	9 x 27	1	12	1600	584	110	263	211	26	22	159	286	439	809	300	306	623
	9 x 27	1	30	1600	584	110	263	211	26	22	159	397	439	986	350	306	623
	11,3 x 31	1	12	2500	611	110	263	238	33	24	159	286	439	809	300	306	623
	11,3 x 31	1	30	2500	611	110	263	238	33	24	159	397	439	986	350	306	623
	11,3 x 31	2	12	5000	761	110	263	388	41	28	207	334	439	809	300	306	623
	11,3 x 31	2	30	5000	761	110	263	388	41	28	207	447	439	986	350	306	623
	11,3 x 31	3	nc	6300	nc	nc	nc	nc	nc	nc	nc	nc	nc	nc	nc	nc	nc
	11,3 x 31	3	nc	7500	nc	nc	nc	nc	nc	nc	nc	nc	nc	nc	nc	nc	nc
	11,3 x 31	2 x 2	nc	10000	nc	nc	nc	nc	nc	nc	nc	nc	nc	nc	nc	nc	nc

The EUROCHAIN VR hoist range

Capacity (kg)	Hoist type	F.E.M.	ISO	Lifting speeds (m/min)	Number of falls	HS lifting motor power (kW)	Gear box lifetime (hours)	Chain dimensions	
63	VR2 0608 b3	3m	M6	8 / 2	1	0,45	3200	4 x 11	
	VR2 0610 b3	3m	M6	10 / 2,5	1	0,45	3200	4 x 11	
	VR2 0616 b3	3m	M6	16 / 4	1	0,45	3200	4 x 11	
	VR2 0620 b3	3m	M6	20 / 5	1	0,45	3200	4 x 11	
125	VR2 128 b3	3m	M6	8 / 2	1	0,45	3200	4 x 11	
	VR2 1210 b3	3m	M6	10 / 2,5	1	0,45	3200	4 x 11	
	VR2 1216 b2	2m	M5	16 / 4	1	0,45	1600	4 x 11	
	VR2 1220 b1	1Am	M4	20 / 5	1	0,45	800	4 x 11	
160	VR2 168 b3	3m	M6	8 / 2	1	0,45	3200	4 x 11	
	VR2 1610 b3	3m	M6	10 / 2,5	1	0,45	3200	4 x 11	
	VR2 1616 b1	1Am	M4	16 / 4	1	0,45	800	4 x 11	
250	VR2 258 b2	2m	M5	8 / 2	1	0,45	1600	4 x 11	
	VR2 2510 b1	1Am	M4	10 / 2,5	1	0,45	800	4 x 11	
	VR5 254 b3	3m	M6	4 / 1,3	1	0,9	1600	4 x 11	
	VR5 258 b3	3m	M6	8 / 1,3	1	0,9	800	4 x 11	
	VR5 2516 b2	2m	M5	16 / 2,6	1	0,9	1600	4 x 11	
	VR5 2520 b1	1Am	M4	20 / 3,2	1	0,9	800	4 x 11	
320	VR2 328 b1	1Am	M4	8 / 2	1	0,45	800	4 x 11	
	VR5 3216 b1	1Am	M4	16 / 2,7	1	0,9	800	4 x 11	
500	VR2 504 b2	2m	M5	4 / 1	2	0,45	1600	4 x 11	new
	VR5 504 b2	2m	M5	4 / 1,3	1	0,45	1600	5 x 14	
	VR5 508 b2	2m	M5	8 / 1,3	1	0,9	1600	5 x 14	
	VR12 504 b3	3m	M6	4 / 1,3	1	0,9	800	5 x 14	
	VR5 5010 b1	1Am	M4	10 / 1,6	1	0,9	1600	5 x 14	
	VR12 508 b3	3m	M6	8 / 1,3	1	1,8	1600	5 x 14	
	VR12 516 b2	2m	M5	16 / 2,6	1	1,8	1600	5 x 14	
	VR12 520 b1	1Am	M4	20 / 3,2	1	1,8	800	5 x 14	
630	VR5 634 b1	1Am	M4	4 / 1,3	1	0,45	800	5 x 14	
	VR5 638 b1	1Am	M4	8 / 1,3	1	0,9	800	5 x 14	
	VR12 6316 b1	1Am	M4	16 / 2,6	1	1,8	800	5 x 14	
800	VR16 816 b3	3m	M6	16 / 2,6	1	2,3	3200	7 x 20	
	VR25 820 b3	3m	M6	20 / 3,3	1	3,6	3200	9 x 27	
1000	VR5 1004 b2	2m	M5	4 / 0,7	2	0,45	1600	5 x 14	new
	VR12 1008 b2	2m	M5	8 / 1,3	1	1,8	1600	7 x 20	
	VR12 1010 b1	1Am	M4	10 / 1,6	1	1,8	800	7 x 20	
	VR16 1012 b3	3m	M6	12,5 / 2	1	2,3	3200	7 x 20	
	VR25 1016 b3	3m	M6	16 / 2,6	1	3,6	3200	9 x 27	
	VR25 1020 b3	3m	M6	20 / 3,3	1	3,6	3200	9 x 27	
	VR12 1004 b3	3m	M6	4 / 0,7	2	1,8	3200	7 x 20	
1250	VR12 1204 b1	1Am	M4	4 / 1,3	1	0,9	800	7 x 20	
	VR12 1208 b1	1Am	M4	8 / 1,3	1	1,8	800	7 x 20	
	VR16 1232 b3	3m	M6	32 / 5	1	2,3	1600	9 x 27	
1600	VR5 1004 b2	2m	M5	4 / 0,7	2	1,8	1600	7 x 20	
	VR12 1604 b2	2m	M5	4 / 0,7	2	1,8	1600	7 x 20	
	VR12 1605 b2	2m	M5	5 / 0,8	2	1,8	1600	7 x 20	
	VR16 1608 b2	2m	M5	8 / 1,3	1	2,3	3200	9 x 27	
	VR25 1612 b3	3m	M6	12,5 / 2	1	3,6	3200	11,3x31	
2000	VR12 2004 b2	2m	M5	4 / 0,7	2	1,8	1600	7 x 20	
	VR12 2005 b1	1Am	M4	5 / 0,8	2	1,8	800	7 x 20	
	VR16 2006 b3	3m	M6	6,3 / 1	2	2,3	3200	9 x 27	
	VR25 2008 b3	3m	M6	8 / 1,3	1	3,6	3200	11,3 x 31	
2500	VR12 2504 b1	1Am	M4	4 / 0,7	2	3,6	800	7 x 20	
	VR16 2504 b3	3m	M6	4 / 0,7	2	2,3	3200	9 x 27	
	VR25 2508 b3	3m	M6	8 / 1,3	1	3,6	1600	11,3 x 31	
3200	VR16 3204 b2	2m	M5	4 / 0,7	2	2,3	1600	9 x 27	
	VR25 3206 b3	3m	M6	6,3 / 1	2	3,6	3200	11,3 x 31	
4000	VR25 4004 b3	3m	M6	4 / 0,7	2	3,6	3200	11,3 x 31	
5000	VR25 5004 b2	2m	M5	4 / 0,7	2	3,6	1600	11,3 x 31	
6300					nc				
7500					nc				new
10000					nc				



Options available

- > Special voltage (power and control).
- > Gear limit switches (2 or 4 steps).
- > Single phase version.
- > Double brake on lifting motor.
- > Manual brake release.
- > Hard wired 48V control.
- > HF radio remote.
- > Audible horn.
- > Light warning.
- > Key switch on Emergency / Stop button.
- > Suspension eye perpendicular instead of upper hook.

- > Self-locking hook.
- > Parallel suspension hook.
- > Special oil NSF H1 for food industry.
- > Special load for hoist.
- > Stainless steel hook block and hook.
- > Foot mounted hoist.
- > Travel limit switches.
- > Low headroom trolley.
- > Swivelling trolley.
- > Double girder trolley.
- > Leading bracket for feeding line.
- > Dual speed trolley (20 & 5 m/min).

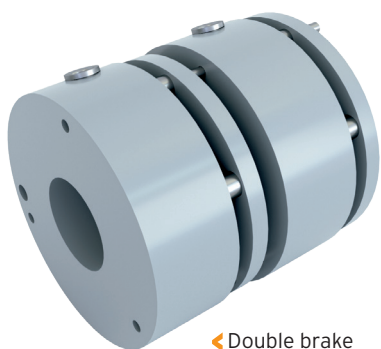

◀ Double brake

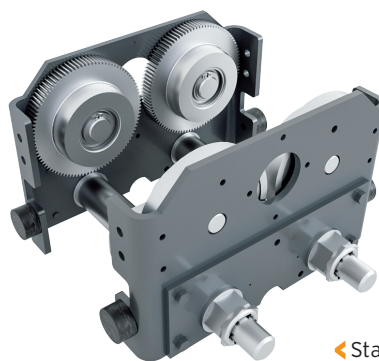

◀ Stainless steel wheels



◀ Light warning



◀ Horn

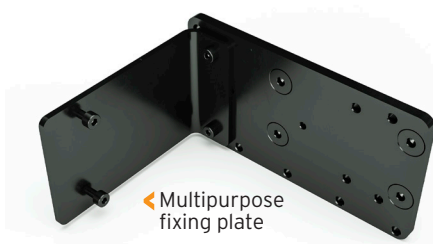

◀ Multipurpose fixing plate



◀ Hard wired control plug



◀ Radio receiver



Stagemaker SR10



Hoist according ATEX EX regulation



Stainless steel Hook and lifting chain

- > Low speed trolley (3 to 10 m/min).
- > Worm gear box.
- > High speed trolley.
- > Stainless steel wheels on trolley.
- > Bigger flange width than 310 mm.
- > Wall control box.
- > IP 66 Protection.
- > High capacity chain bag.
- > Extra set of document.
- > Special paint.

- > Additional button on pendant.
- > Direct voltage control instead of low voltage.
- > Rain cover.
- > Reinforced protection.
- > Total protection zone 22.
- > Tropicalised protection.
- > Hoist according CSA specifications.
- > Hoist according ATEX EX.
- > Hoist for entertainment application (Stagemaker SR).

Lifting standards and rules



CE directive. Since 29th December 2009 a new Machine Directive (2006/42/CE) has been in application for the assembly and trade in new machines marketed from 2010. This new text completes the former Directive, which was a compilation of 600 standards from 1995. This directive requires manufacturers to harmonise their production according to certain provisions, standards, national rules and technical specifications.

F.E.M. European Federation of Handling Industries.

S.W.P. Safe Working Period. The unit's safe working period is determined according to the average usage time for the lifting mechanism, the load spectrum and the user group. After this period, a general overhaul recommended by the manufacturer is necessary.

User group. Depending on the FEM classification, two fundamental

criteria must be taken into account: the use made of the hoist and the operating classes (related to the average daily usage time and the machine's lifting movement).

ISO standard. The usage groups may also be defined as ISO groups (1Am = M4, 2m = M5, 3m = M6, etc).

Usage conditions.

> **Light service.** Machine subject exceptionally to maximum use and frequently to very low use.

> **Medium service.** Machine subject quite often to maximum use and frequently to low use.

> **Heavy service.** Machine subject frequently to maximum use and frequently to medium use.

> **Very heavy service.** Machine subject regularly to use close to maximum use.

Average daily operating time in hours				≤ 0,5		≤ 1		≤ 2		≤ 4		≤ 8		≤ 16	
Operating class				V0,25	T2	V0,5	T3	V1	T4	V2	T5	V3	T6	V4	T7
Usage conditions	1	L1	Light					1Bm	M3	1Am	M4	2m	M5	V4	M6
	2	L2	Medium			1Bm	M3	1Am	M4	2m	M5	3m	M6		
	3	L3	Heavy	1Bm	M3	1Am	M4	2m	M5	3m	M6				
	4	L4	Very heavy	1Am	M4	2m	M5	3m	M6						
Group								1Bm	M3	1Am	M4	2m	M5	3m	M6
Operating factor*								25 %		30 %		40 %		50 %	
Number of start-ups per hour								150		180		240		300	

■ F.E.M. 9511 standard classification ■ ISO standard classification.

* Operating factor in % = $\frac{\text{Rise time} + \text{Lower time}}{\text{Rise time} + \text{Stop time} + \text{Lower time} + \text{Stop time}} \times 100$



VERLINDE is:

- The leading French manufacturer and exporter of lifting and handling equipment.
- A comprehensive range of 30 groups of lifting equipment from 60 to 250,000 kg.
- ISO 9001 Quality control certified and ISO 14001 Environmental Management Systems.



Our references

Metallurgy, Mechanics, Nuclear ➤ ArcelorMittal - Unimetal - Stein - NFM - Framatome - Alstom

Chemicals, Petrochemicals industry ➤ Sanofi Aventis - Du Pont De Nemours - Total

Aeronautical industry ➤ Aérospatiale - Airbus - Eurocopter - Air France - Aéroport de Paris - Snecma - Dassault Aviation

Agri-food industry ➤ Nestlé - Danone - Bel - Palamatic - Tetrapak - Lactalis

Automobile industry ➤ Renault - Peugeot - Citroën - Scania - Ford - RVI - Volkswagen - Michelin - Massey Ferguson - Manitou - Toyota Industrial Equipment

Other sectors ➤ EDF - SNCF - RATP - Spie - Degremont - Eiffage - Polysius - Baudin Chateaufort



In France:

A sales network and after sales service points, EUROPONT travelling crane construction plants and a distributor network.

Abroad:

A customer service in more than 92 countries.



2, boulevard de l'Industrie - B.P. 20059 - 28509 Vernouillet cedex - France
Telephone : (33) 02 37 38 95 95 - Fax : (33) 02 37 38 95 99
Internet : www.verlinde.com